

I-SOLUTION 單點恆壓控制

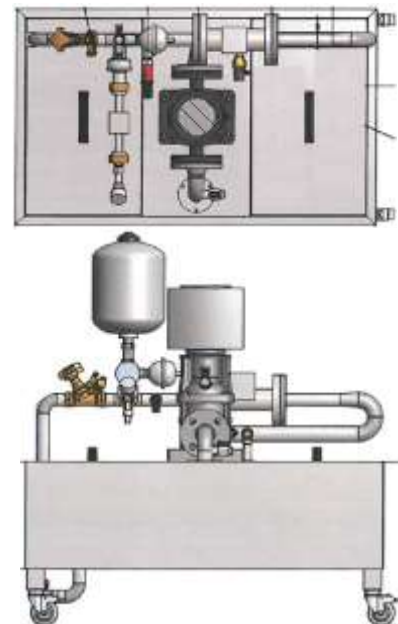

As seen from the drawings and the diagram, the standard CRNE demo consist of the following components:

- Pump: CRNE3-5 with a 0.75 kW MGE
- PT: Pressure transmitter, 0-10 bar, 4-20 mA
- Q1: Flow transmitter, 0.0 – 12 m³/h, 4-20 mA
- Q2: Flow transmitter, 0.0 – 6 m³/h, 4-20 mA
- DT1: Diaphragm tank, 0.16 litres
- DT2: Diaphragm tank, 5 litres
- G: Pressure gauge
- V1: Normal tap
- V2: Commissioning valve with setting scale DN32
- V3: Shut-off valve for diaphragm tank
- V4: Bottom valve

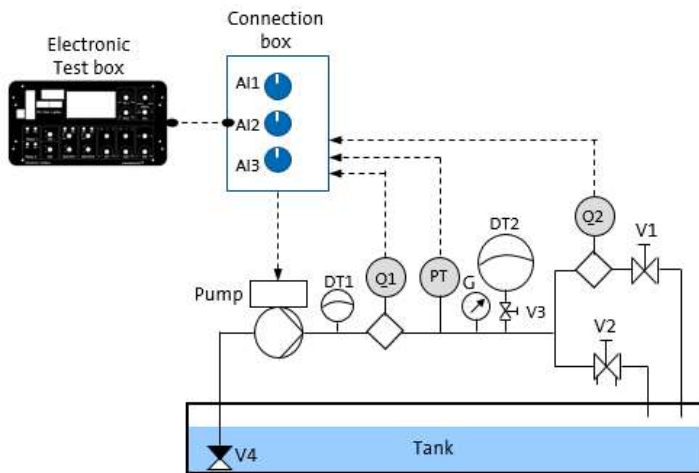