

I-SOLUTION 恆溫/流量控制機組

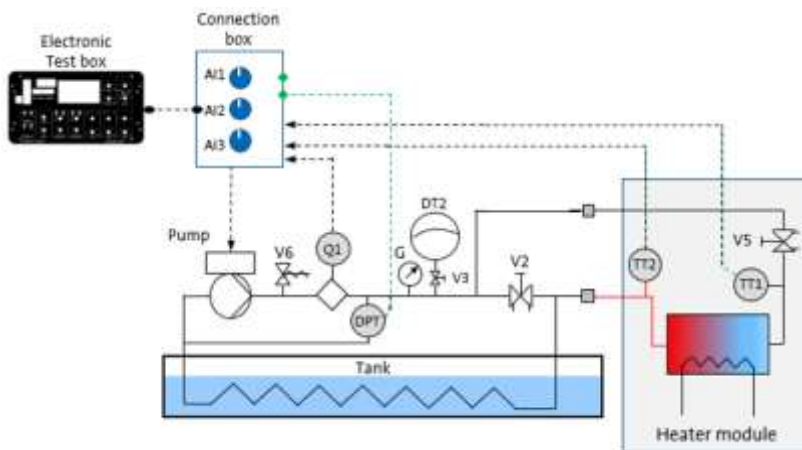

The demo consists of the following components

- Pump: TPE3 32-180-S, with 0.55 kW MGE incl. display and FM300 board
- TT1: Temperature transmitter, 0-100 °C, 4-20mA, connected to AI1 via the connection box
- TT2: Temperature transmitter, 0-100 °C, 4-20mA, connected to AI3 via the connection box
- Q1: Flow transmitter, 0.0 – 25 m³/h, 4-20 mA, connected to AI2 via the connection box
- DPT: Diff. Pressure Transmitter, 0-2.5 bar, 4-20 mA, XLR connector
- DT2: Expansion tank, Tank: Fam Baby Star Cat.1, 2 liter
- A small storage tank with a 370W electrical heating element.
- V2: Commissioning valve with setting scale
- V3: Shut-off valve for diaphragm tank (not present)
- V5: Commissioning valve for controlling flow in heater module
- V6: Pressure relief valve
- G: Pressure gauge

